

GRID SPECIFICATIONS

- Pre-engineered and factory-produced aluminum structural ceiling grid with continuously threaded slots (3/8"-16 & 1/2"-13)
- Grid consists of Main Runners with notches for precise location and connection of coped Structural Tees using four screw connectors
- Capable of supporting power modules, light fixtures, cable trays, partitions and other accessories
- Load performance: See table on page 4
- System Weight:
 - 2'x2' Grid: 1.1 lb/ft²
 - 2'x4' Grid: 0.9 lb/ft²
- Grid member center to center spacing can be selected to accommodate project specific specs. (see page 3 and 4 for more information)
- All bolt connections to the top slot or bottom of the grid should be tightened flush to a washer with a torque value between 20 in-lbs and 30 in-lbs.

CONNECTOR SPECIFICATIONS

- High Strength Steel Construction
- Attaches to grid members with (4) 3/8"-16 screws
- 1/2"-13 turnbuckles thread into hanging connectors on mains
- Tee and Corner connectors for perimeter installation

COMPONENTS

- 144" Main Runner / 144" Perimeter Angle
- 24" Structural Tee / 48" Structural Tee
- Field Connector / Hanging Connector
- Perimeter Connector / Corner Connector
- 3/8"-16 x 1-1/4" Screws w/ 3/8" Lock washer
- 3/8"-16 x 1-1/2" Screws w/ 3/8" Spacers for Hanging & Field Connector overlap condition.
- Splice connector for ends of mains (See Pg 5)
- 1/2"-13 x 8" Turnbuckle Assembly
- Ceiling Hold Down Clips (optional)
- Factory-Applied Gasket (optional)
- Ceiling Tiles & Tate LED Lights (optional)
- Threaded Rod Connection to Building (supplied by others)

GRID OPTIONS

Grid Color: White Black Other

Hanger Spacing: _____ x _____

Standard Grid Spacing Options (see p.3 for detail)

- 24" / 24" 24" / 48"
- 24 5/8" / 24 5/8" 24 5/8" / 48 5/8"
- Custom Grid Spacing Options Available

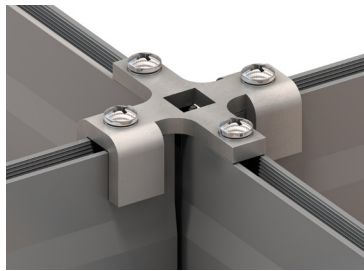

Field Connector

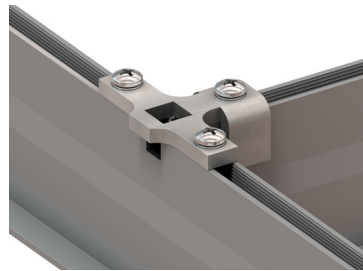

Duo T-Connector

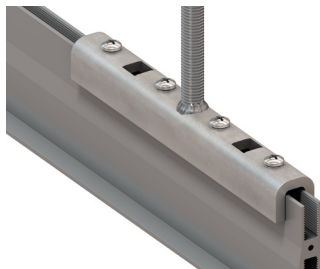

Hanging Connector

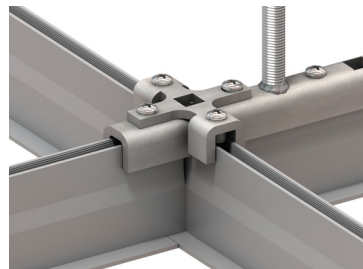

Hanging & Field Connector w spacer

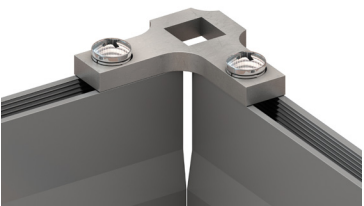

Corner Connector

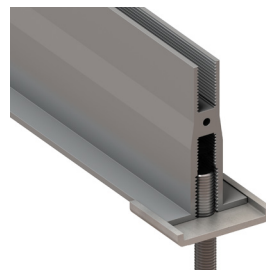

Duo Anti-splay Washer
(used for suspending loads from 1/2" slot)

TATE DUO PROFILE OPTIONS

3/8"-16 & 1/2"-13 Bottom Slot - Field & Floating Perimeter

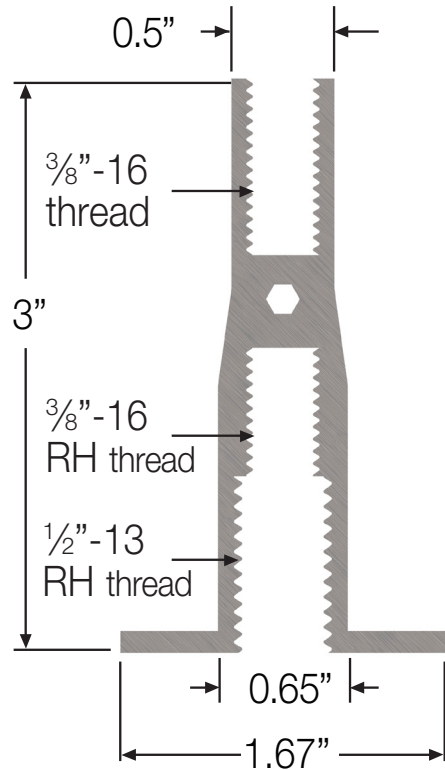

- Continuous threaded 3/8"-16 top slot
- Continuous threaded 3/8"-16 and 1/2"-13" dual bottom slot
- Utilizes standard hardware connectors and features of Tate Duo structural ceiling

3/8"-16 Fixed Perimeter

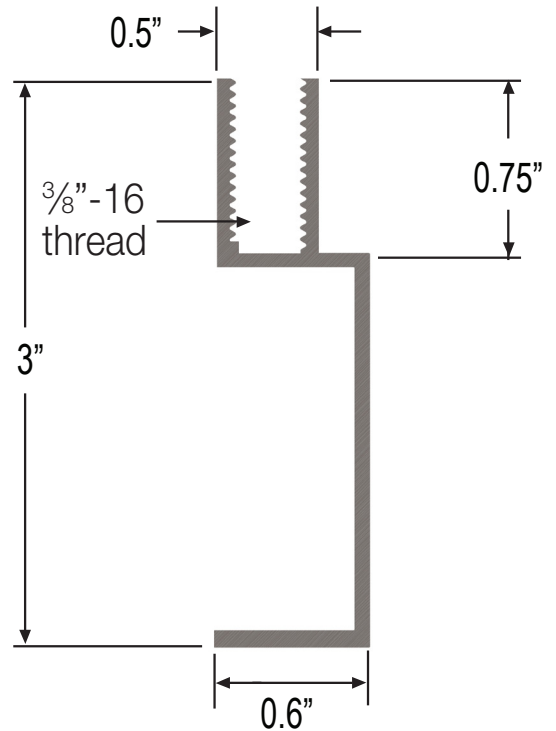

- Continuous threaded 3/8"-16 top slot
- Slim profile perimeter design
- Utilizes standard hardware connectors and features of Tate Duo structural ceiling

GRID SPACING AND TILE SIZING

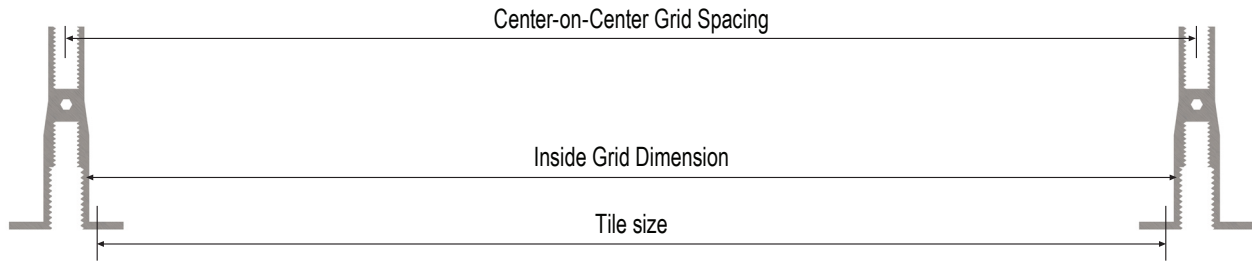

If you want the Grid Spacing to be on a 24" x 24" or 24" x 48" module size, use this table to determine tile size requirement:

Grid Profile	Grid Spacing (L x W)	Tile Size (L x W)
3/8"-16 Bottom Slot & 1/2"-13 Bottom Slot	24" x 24"	23 1/8" x 23 1/8" +/- 1/8"
	24" x 48"	23 1/8" x 47 1/8" +/- 1/8"

Note: Maximum Tile Size = Inside Grid Dimension minus 1/8". Minimum Tile Size is based on a minimum overlap on the extrusion flange of 1/8" when the tile is shifted all the way to one side.

If you want the Grid Spacing to be on a larger module size to fit standard 24" x 24" or 24" x 48" nominal tile sizes, use this table:

Grid Profile	Grid Spacing (L x W)	Tile Size (L x W)
3/8"-16 Bottom Slot & 1/2"-13 Bottom Slot	24 5/8" x 24 5/8"	23 3/4" x 23 3/4" +/- 1/8"
	24 5/8" x 48 5/8"	23 3/4" x 47 3/4" +/- 1/8"

Note: Maximum Tile Size = Inside Grid Dimension minus 1/8". Minimum Tile Size is based on a minimum overlap on the extrusion flange of 1/8" when the tile is shifted all the way to one side.

Sizing Based on 24" x 48" Grid Spacing

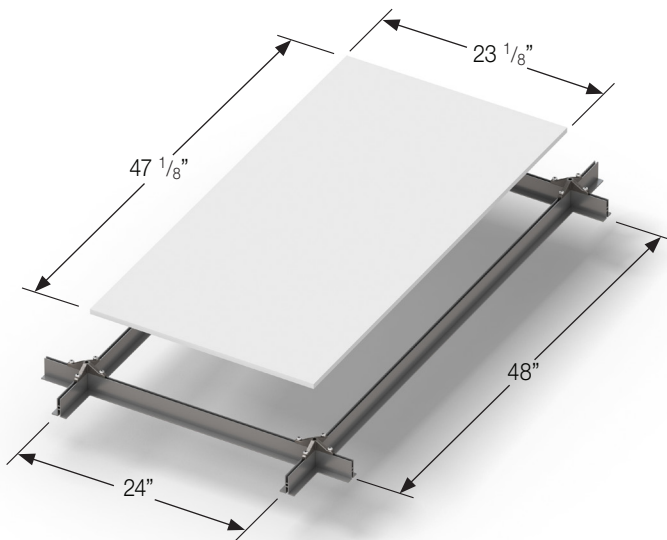

Sizing Based on 24" x 48" Nominal Tile Size

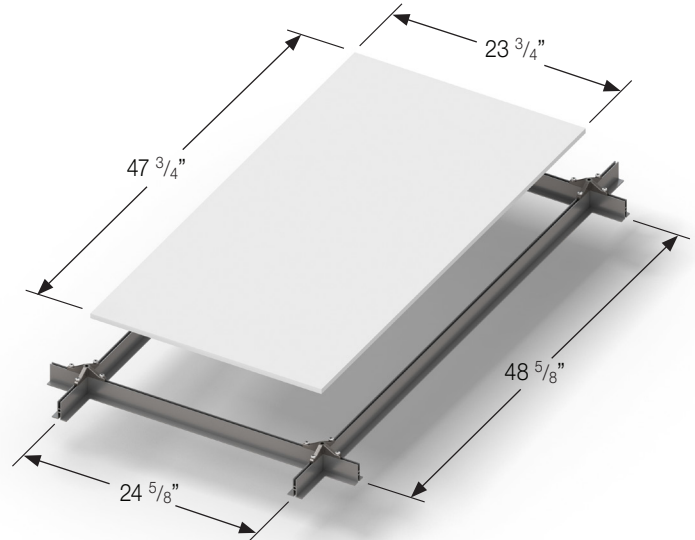

HOLD DOWN CLIPS

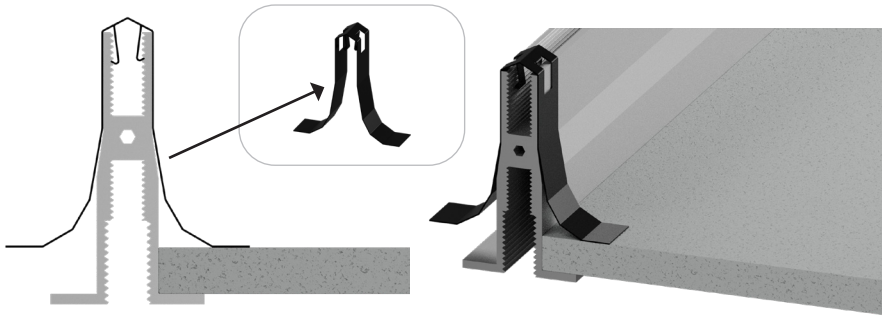

- Hold down clips can be provided with the Tate Duo system as an option.
- Two hold down clips are recommended per tile.
- Hold down clips are installed by pressing them into the top thread by hand or lightly tapping them with a mallet.
- Hold down clips are designed for use with 1/2" - 1" thick ceiling tiles
- PN44404

PERFORMANCE CRITERIA

The bottom side of the structural grid is available with a 3/8"-16 & 1/2"-13 continuous threaded slot for mounting items directly to the grid. Refer to the table below for load performance details on the grid and connections.

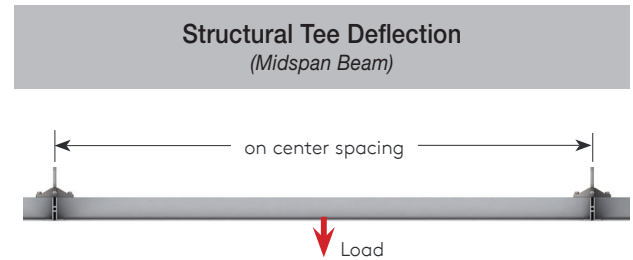
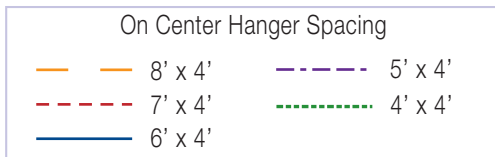
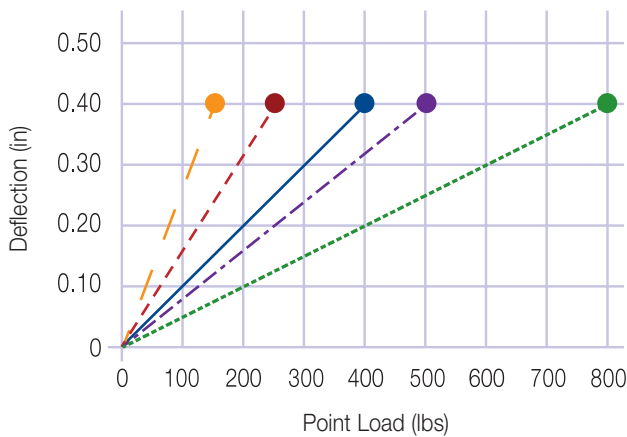

Calculate midspan beam deflection at any point below yield

$$S = \frac{WL^3}{48EI}$$

$S = \text{Deflection}$
 $W = \text{load}$
 $L = 48\text{in}$
 $E = 10 \times 10^6 \text{ lbs/in}^2$
 $I = 0.67 \text{ in}^4$

On Center Hanger Spacing	Max. Uniform Load (lb/ft ²)	Max. Safe Working Load (Point Load) (lbs)	Midspan Deflection at Max. Safe Working Load	Safety Factor
4' x 4'	112	800	0.22"	2x
5' x 4'	90	500	0.24"	2x
6' x 4'	75	400	0.36"	2x
7' x 4'	64	250	0.37"	2x
8' x 4'	56	150	0.34"	2x

Max safe working load based hanging points no less than 4' apart in any direction.

FIELD CONNECTOR ASSEMBLY

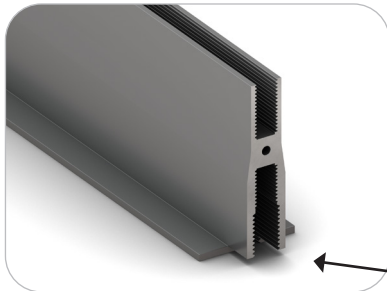

Structural Tee coped for simplified installation and stronger connections

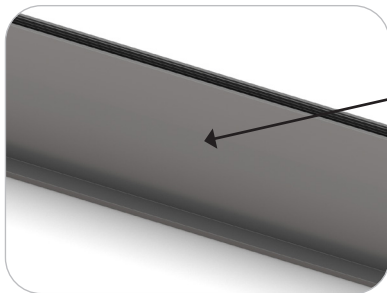

Main Runners in 12' (3.6m) lengths

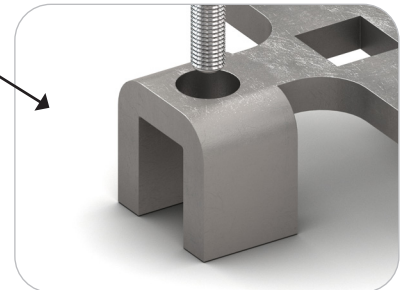
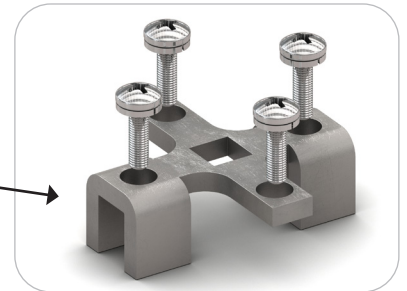
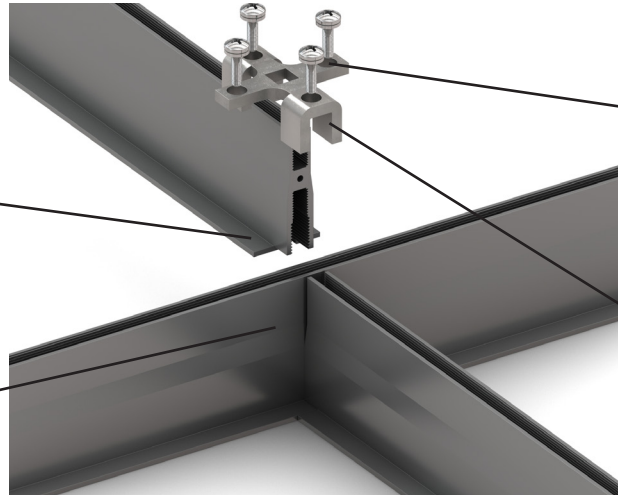

U channel connector to align with grid and prevent racking

SPLICE CONNECTOR

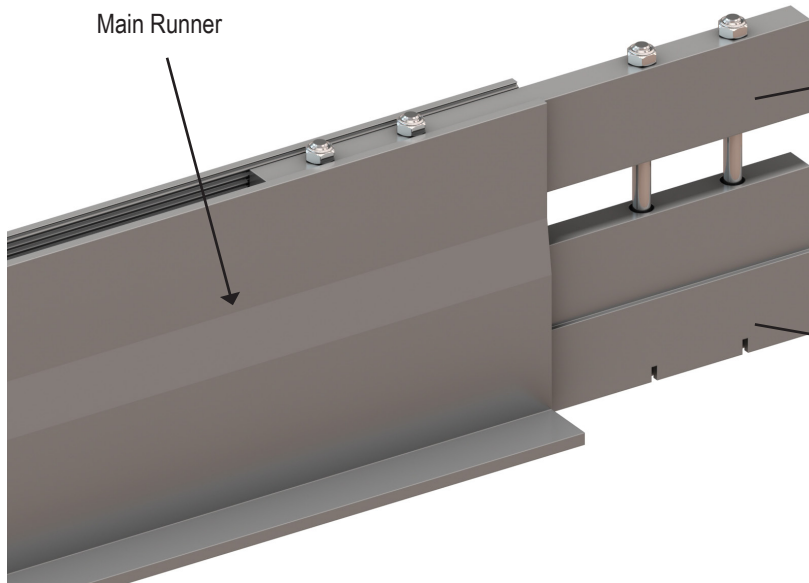

Duo main Splice is designed for additional support at the ends of each Main Runner.

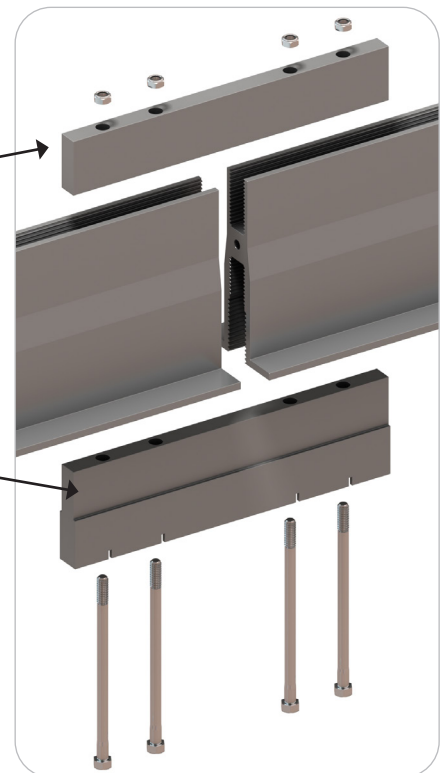

PERIMETER DETAILS

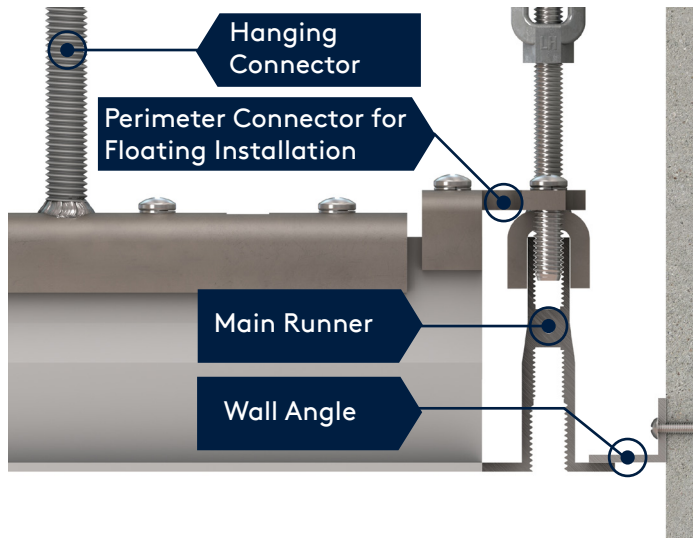

Floating Installation Detail

Main Runners are utilized when installing with a floating detail. When installing with a floating perimeter, Perimeter Connectors can be utilized to align the main runner with the grid while installing close enough to the wall so that angle can be used to fill the void. A hanger is required at the end of each tee to ensure full load rating.

Additionally it is recommended to utilize a Wall Angle attached to the perimeter.

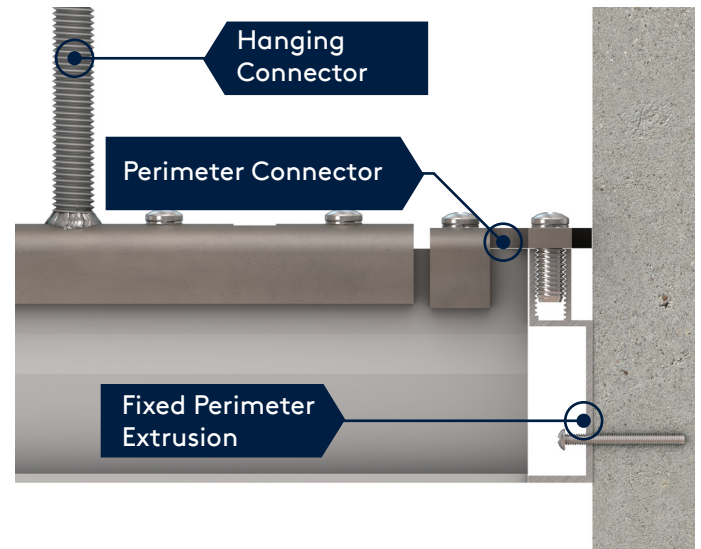

Fixed Installation Detail

Perimeter Extrusions are designed to create a fixed perimeter detail. Perimeter Extrusions can be cut on site to desired length when assembled along perimeter walls. Perimeter Extrusions can also be bolted directly to the wall with appropriate fasteners for the wall type. A hanger is required at the end of each tee to ensure full load rating.

TURNBUCKLE ASSEMBLY

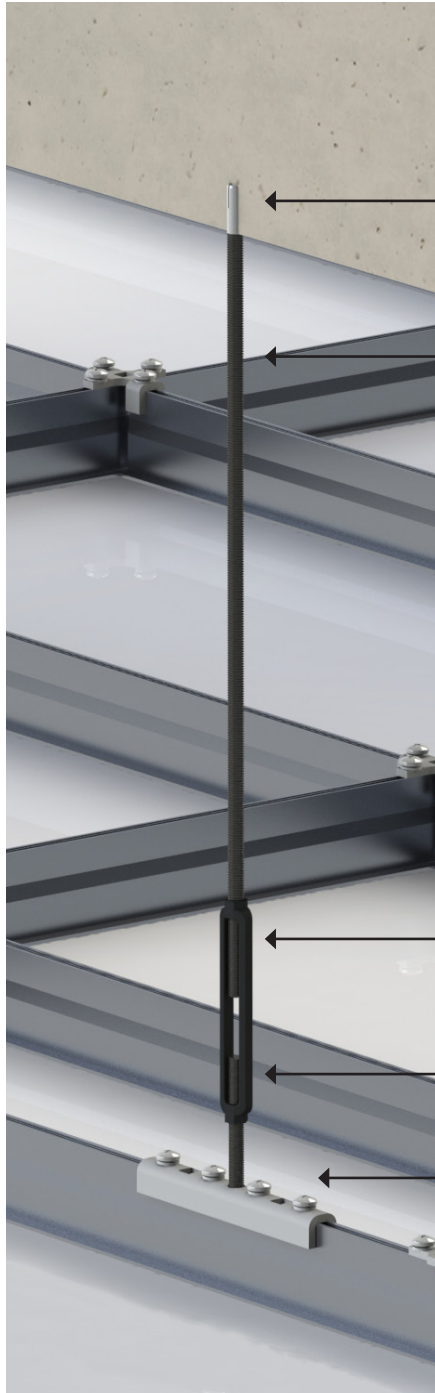

Internally Threaded Anchor or Clamp
(Supplied by others)

RH 1/2"-13 Threaded Rod and
connection to building structure
(Supplied by others)

1/2"-13 LH/RH x 8" Turnbuckle
(Height adjustable)

1/2"-13 Threaded Starter Rod into
Turnbuckle from Hanging Connector

1/2"-13 LH Threaded Rod welded to
Hanging Connector

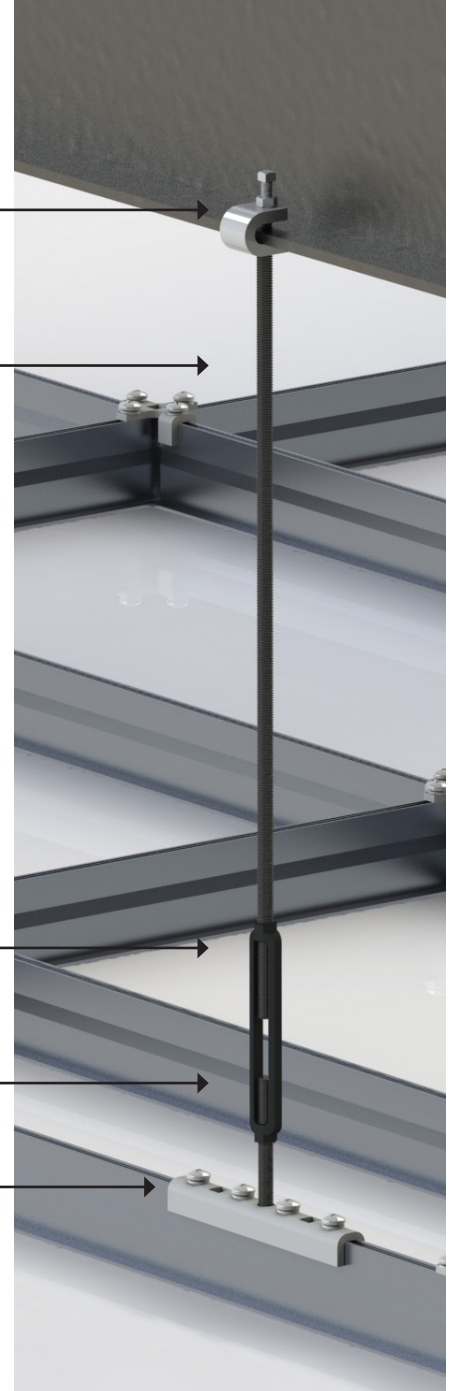

Safety Guidelines

THIS INFORMATION MUST BE SHARED WITH ALL SERVICE PROVIDERS WHO INTEND TO SUSPEND SERVICES FROM THE TATE DUO SYSTEM

Tate Duo is a structural ceiling system designed to support static vertical loads. When installing services to the bottom $\frac{3}{8}$ "-16 or $\frac{1}{2}$ "-13 threaded channel, the following instructions must be adhered to:

1. Tate Duo is limited to a maximum point load of 800 lbs or distributed load of 112 lb/ft^2 at 4ft hanger spacing. See data table for ratings at other spans.
 - a. Exceeding these values may cause a failure in the system.
2. When hanging equipment from the $\frac{1}{2}$ " slot, an anti-splay washer must be used to prevent separation of the slot under heavy loads.
3. Torque the threaded rod or bolts between 20 in-lbs and 30 in-lbs. Over torquing will damage the threaded slots reducing the load capacity of the Tate Duo System.
 - a. Failure to adhere to this may result in the shearing of bottom slot threads reducing the load capacity of the Tate Duo system.
4. Equal care must be taken during the installation of the Tate Duo to install the top screws connecting the Tate Duo to the suitable connector at a torque limit between 20 in-lbs and 30 in-lbs.
 - a. Failure to adhere to this may result in the shearing of top slot threads reducing the load capacity of the Tate Duo system.
5. Only screws supplied by Tate should be used on the top slot.
 - a. Failure to adhere to this may result in the reduction of the load capacity of the Tate Duo system.
6. Do not impose a dynamic load on the connection to Tate Duo. During installation of supported services, bracing is required to prevent dynamic load on the Tate Duo ceiling.
 - a. Moment forces imposed on the Tate Duo system may cause failure of the connection between the services and the Tate Duo system.
7. All bottom thread fixings should be completed with suitable washers.
8. Tate Duo is NOT a walk-on ceiling.
9. In certain conditions the loading capacity of the Tate Structural Ceiling System may be greater than the loading capacity of the building structure and/or means of attachment to the building structure. Consult with a licensed structural engineer to obtain site specific recommendations regarding the attachment of the Tate Structural Ceiling System and any associated loading to the building structure.
10. Structural ceiling systems as a whole shall be analyzed and designed to local codes by a qualified engineer.

