

Tested in accordance with CISCA recommended procedures for raised access floors.

To view product details



ICSF Concore[®] 2500 Panel

Tate's Concore[®] 2500 raised access floor panel is intended for heavy industry applications with a Design Load requirement of 11.1kN or less and is engineered to meet Tate Standards per CISCA testing methods

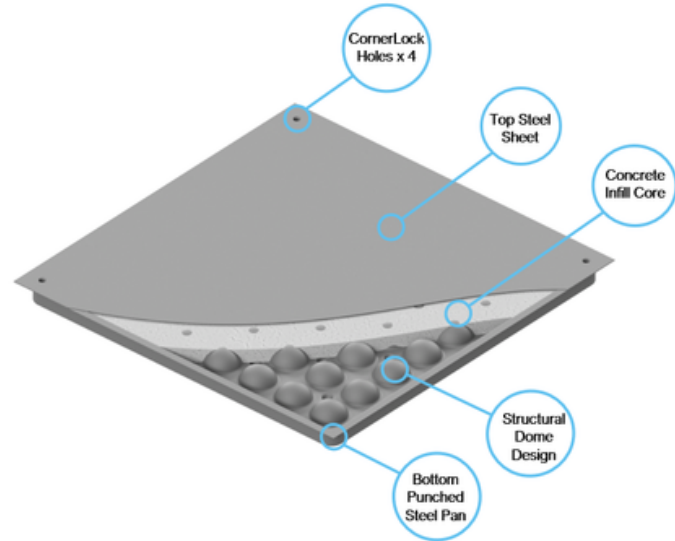

Specifications (Bare Finish Panel)

Panel Weight:	21kg
Panel Size:	600mm x 600mm x 35.65mm
Panel Core:	Cementitious compound
Construction:	Spot welded assembly
Finish:	Powder coated grey for corrosion protection

Understructure:	Bolted Stringer system
Floor Heights:	Standard FFH range: 150mm - 1,000mm
Cover Options:	Factory applied HPL or Vinyl options
Slip Rating:	AS 4586: Dry = D1 Rating & Wet = P2 Rating
Fire Rating:	AS 9239.1: CRF \geq 4.5 kW/m ² & Smoke Development \leq 750 %/min

System Structural Performance

Static Loads			Rolling Loads		Impact Load
Concentrated Load	Ultimate Load	Factor of Safety	10 Passes	10,000 Passes	Drop Impact Load
11.1kN	22.2kN	2	11.1kN	8.9kN	0.89kN

- Design load is the Ultimate Load divided by the Factor of Safety
- Static, Rolling & Impact Load tests are performed using CISCA Recommended Test Procedures for Access Floors by 3rd Party Independent
- Concentrated Load is based on Permanent Set Deflection \leq 0.7mm and Rolling Loads are based on Permanent Set Deflection \leq 1.02mm

System Type	System Weight
ICSF2500 Bolted Stringer System	65 kg/m ² (150mm FFH)

Bolted Stringer System

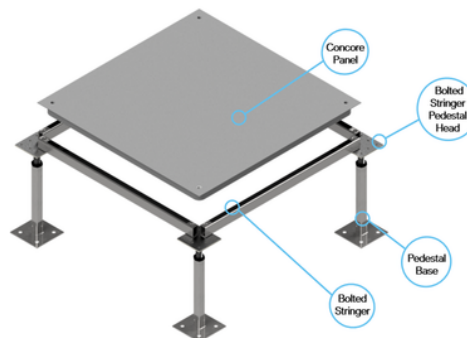



ICSF Concore[®] 2500 Panel

Panel Detail (Bare Finish)

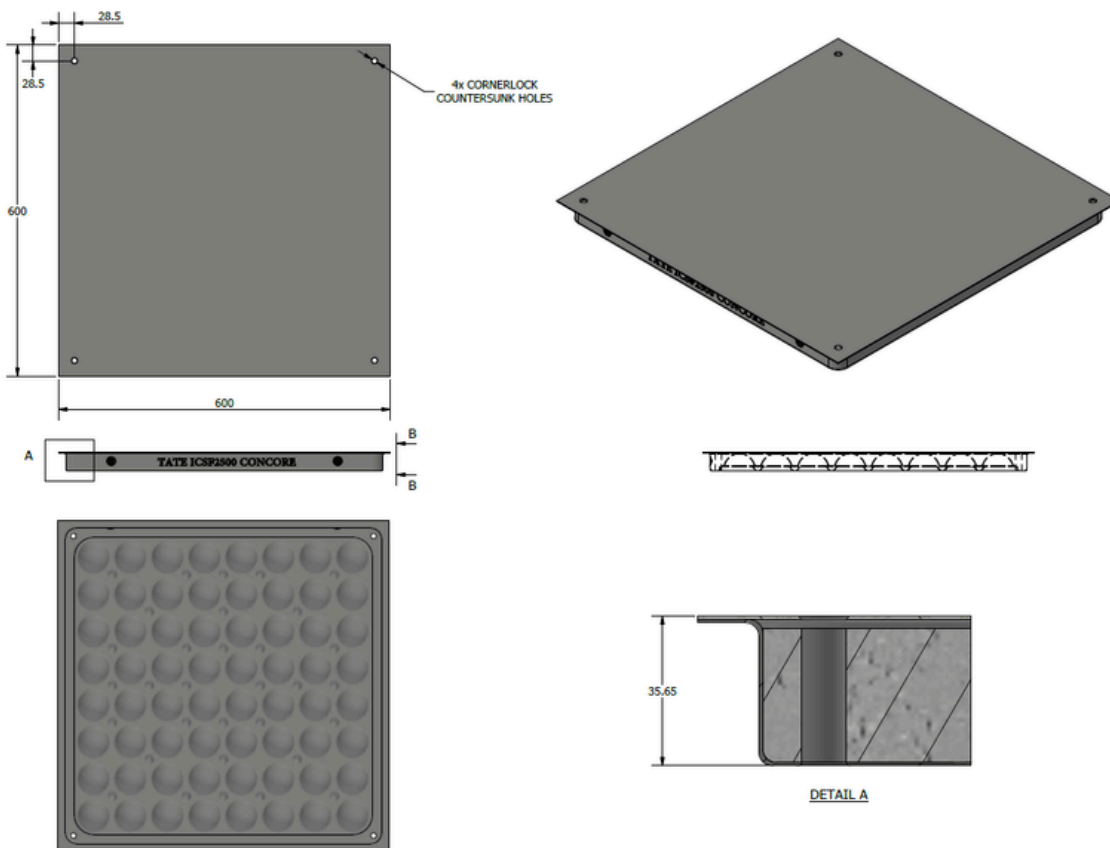

Pedestal Options

Tate APAC Technical Team will provide guidance on selecting the optimal pedestal system, along with fixing method to support the **Concore 2500 Panel**, ensuring compliance with structural load requirements, finished floor heights, acoustic and seismic performance criteria. A range of engineered understructure systems are available to accommodate diverse project specifications and performance standards.

Sustainability



- Supported by a third-party verified EPD providing transparent, independently assessed impact data.

