

AMERICAS
REGION



Tate.[®]

IMPERIAL DATA SHEET INFORMATION

Tate Grid

Aluminum Structural Ceiling
Grid System for Data Centers

tateglobal.com

**BUILDING A
SMARTER WORLD
TOGETHER.**

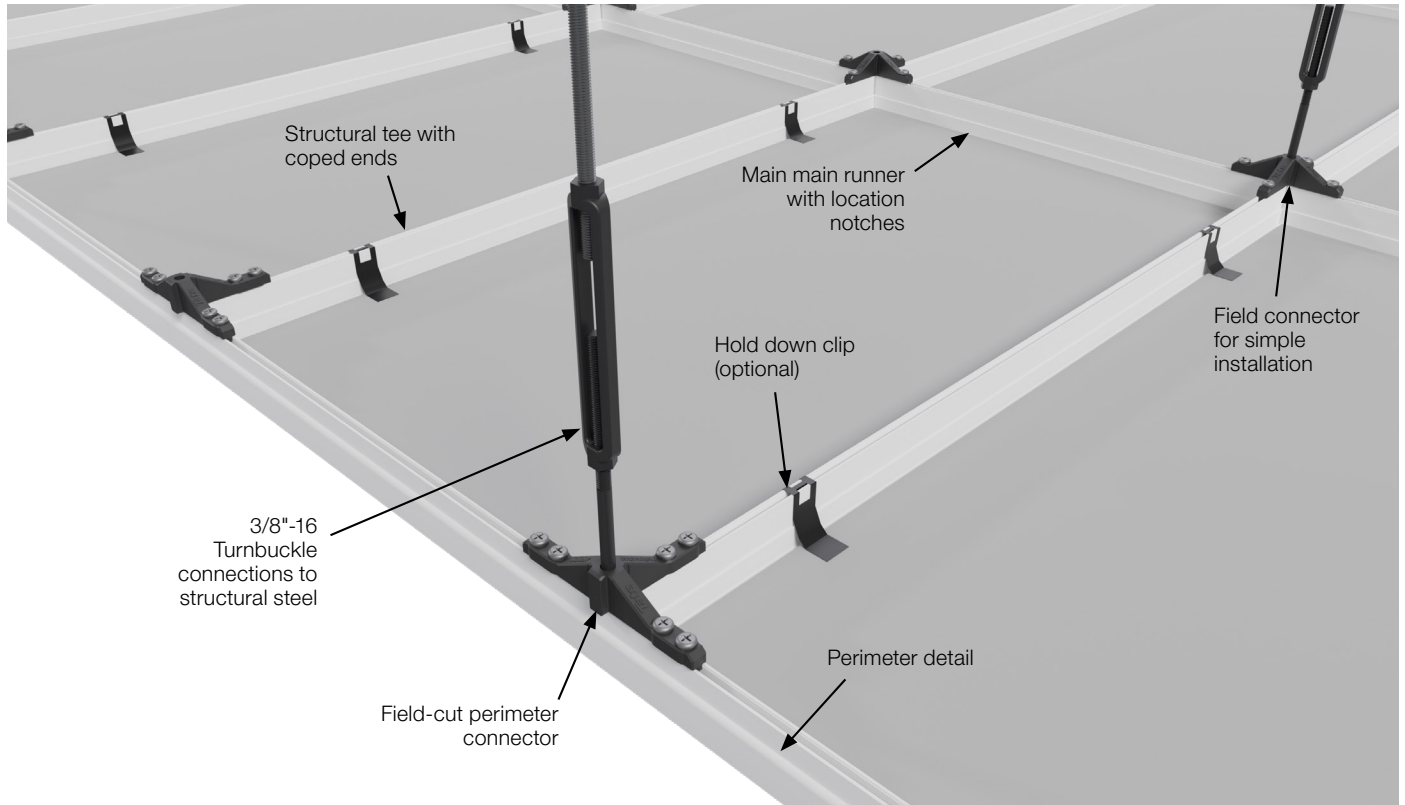

Grid Specifications

- Pre-engineered and factory produced aluminum structural ceiling grid with continuously threaded 3/8"-16 bottom slot
- Grid consists of Main Runners with notches for precise location and connection of coped Structural Tees using four screw connectors
- Capable of supporting power modules, light fixtures, cable trays, partitions, and other accessories
- Load performance based on building connection spacing of 4 ft. on center
 - Max grid point load at midspan of 380 lbs.
 - Max grid uniform load of 50 lbs/ft²
- System Weight:
 - 2'x2' Grid: 0.9 lb/ft²
 - 2'x4' Grid: 0.7 lb/ft²
- Grid member center to center spacing can be selected to accommodate project specific specs. (see page 3 for more information)
- All bolt connections to the top slot or bottom of the grid should be tightened flush to a washer between a torque value of 20 in-lbs and 30 in-lbs.

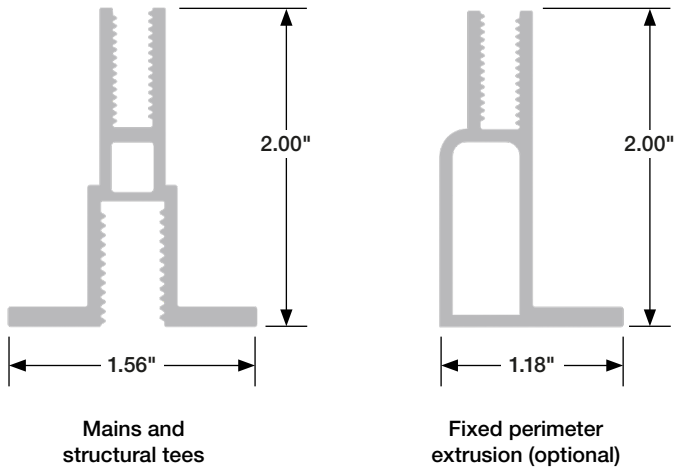

Components

- 144" Main runner / 144" Perimeter main
- 24" Structural tee / 48" Structural tee
- Field connector / XL connector
- Perimeter connector
- 1/4"-20 x 1-1/8" screws w/ 1/4" lock washer
- 3/8"-16 x 7" Turnbuckle assembly with starter rod
- Ceiling hold down clips (optional)
- Factory applied gasket (optional)
- Ceiling tiles & Tate LED (optional)
- Threaded rod connection to building (supplied by others)

Connector Specifications

- High strength cast steel
- Corrosion resistant
- Ribs on connector to engage with grid and prevent racking
- Attaches to grid members with 1/4"-20 screws
- 3/8"-16 turnbuckles with starter rod threads into connectors on a nominal 4'x4' spacing
- On site modifiable connectors for perimeter installation



Field connector



Perimeter & XL connector for main to main connections

Grid Options

- Grid Color White Black Other
- Standard Grid Spacing Options (see P.3 for detail)
- 24" / 24"
 - 24" / 48"
 - 24-1/2" / 24-1/2"
 - 24-1/2" / 48-1/2"
 - Custom Grid Spacing Options Available



Quick and easy main and cross tee connections

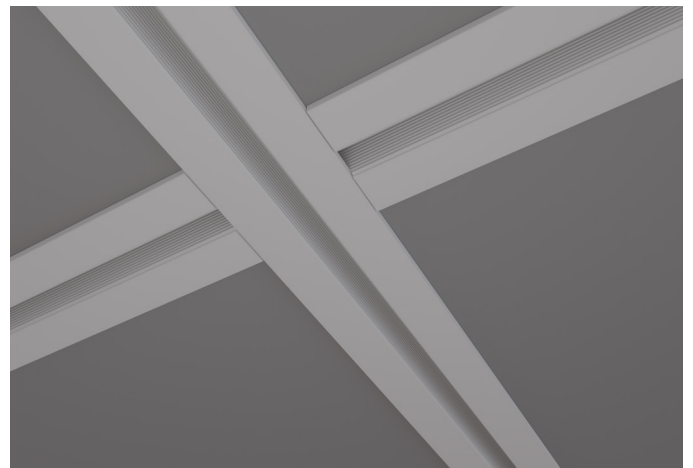

Pre-threaded slot for easy attachment of equipment

Profile Options

3/8"-16 Bottom Slot - Field & Floating Perimeter

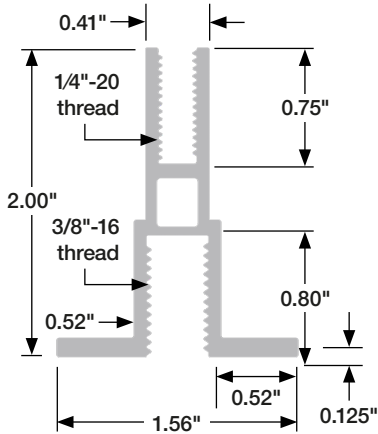

- Continuous threaded 1/4"-20 top slot
- Continuous threaded 3/8"-16 bottom slot
- Utilizes standard hardware connectors and features of Tate Grid

Fixed Perimeter

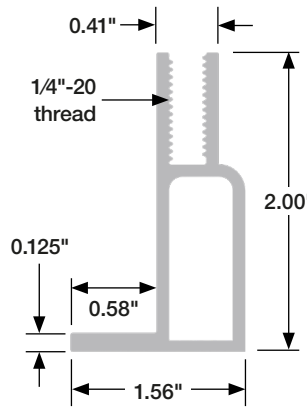

- Continuous threaded 1/4"-20 top slot
- Intended for fixed perimeter installation areas (See page 6)
- Utilizes all standard hardware connectors and features of Tate Grid

Tate Grid End Insert

The Tate Grid end insert is used for additional support at the end of the uncoped (field cut) Tate Grid structural tee.

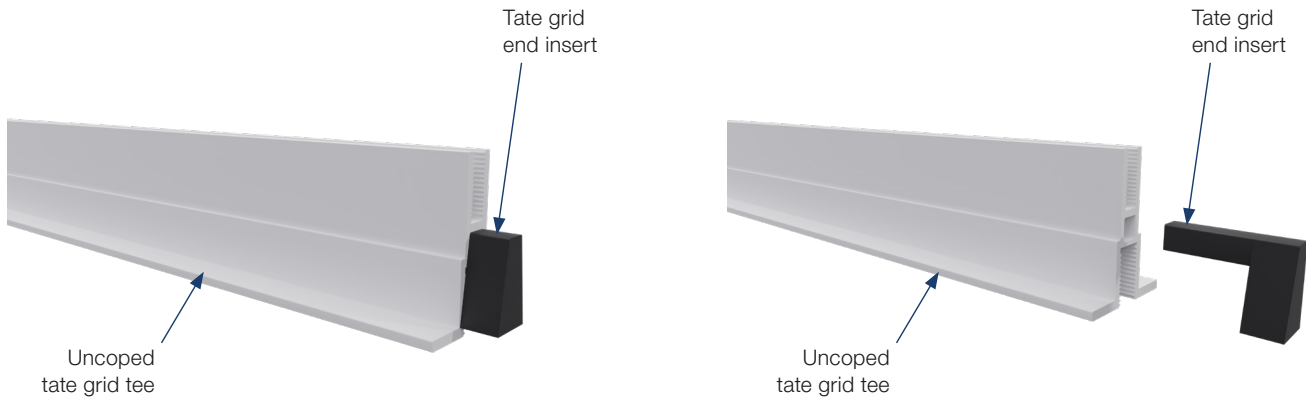

Standard Grid Spacing and Tile Sizing

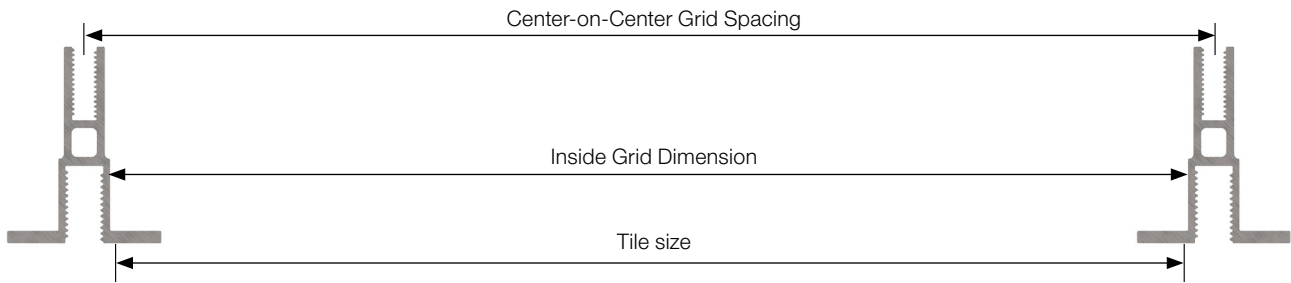

If you want the grid spacing to be on a 24" x 24" or 24" x 48" module size, use this table to determine tile size requirement:

Grid Profile	Grid Spacing (L x W)	Trim Size (L x W)	Hanger Spacing
3/8"-16 Bottom Slot	24" x 24"	23-7/32" x 23-7/32" +/- 1/8"	48" x 48"
3/8"-16 Bottom Slot	24" x 48"	23-7/32" x 47-7/32" +/- 1/8" (see example below)	48" x 48"

Note: Maximum Tile Size = Inside Grid Dimension minus 1/8". Minimum Tile Size is based on a minimum overlap on the extrusion flange of 1/8" when the tile is shifted all the way to one side.

Grid Profile	Grid Spacing (L x W)	Trim Size (L x W)	Hanger Spacing
3/8"-16 Bottom Slot	24-1/2" x 24-1/2"	23-3/4" x 23-3/4" +/- 1/8"	49" x 49"
3/8"-16 Bottom Slot	24-1/2" x 48-1/2"	23-3/4" x 47-3/4" +/- 1/8" (see example below)	49" x 48-1/2"

Note: Maximum Tile Size = Inside Grid Dimension minus 1/8". Minimum Tile Size is based on a minimum overlap on the extrusion flange of 1/8" when the tile is shifted all the way to one side.

Sizing Based on 24" x 48" Grid Spacing

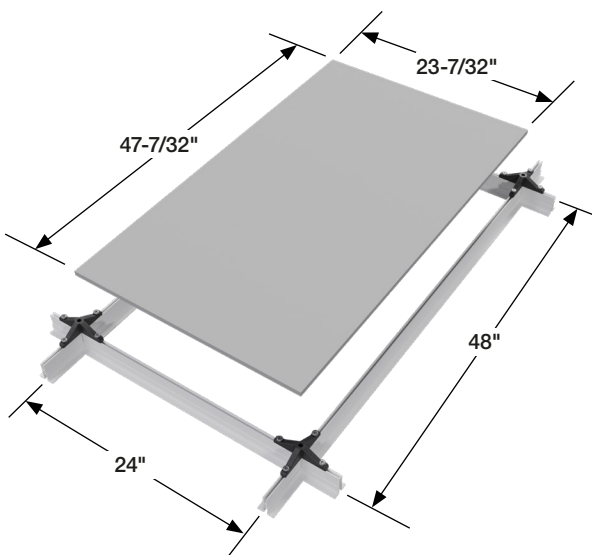

Sizing Based on 24" x 48" Nominal Tile Size

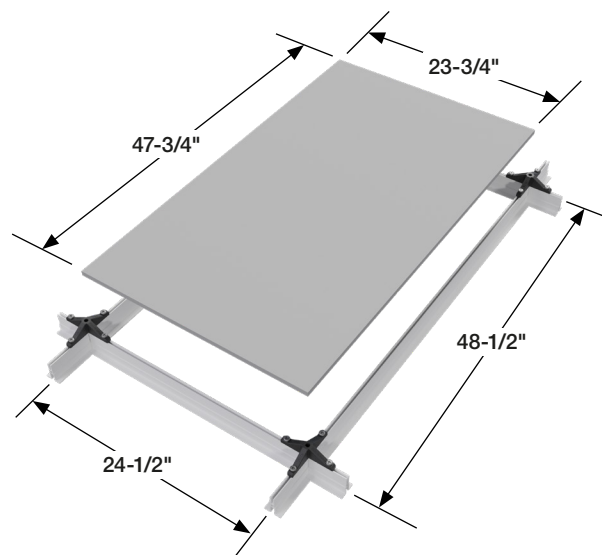

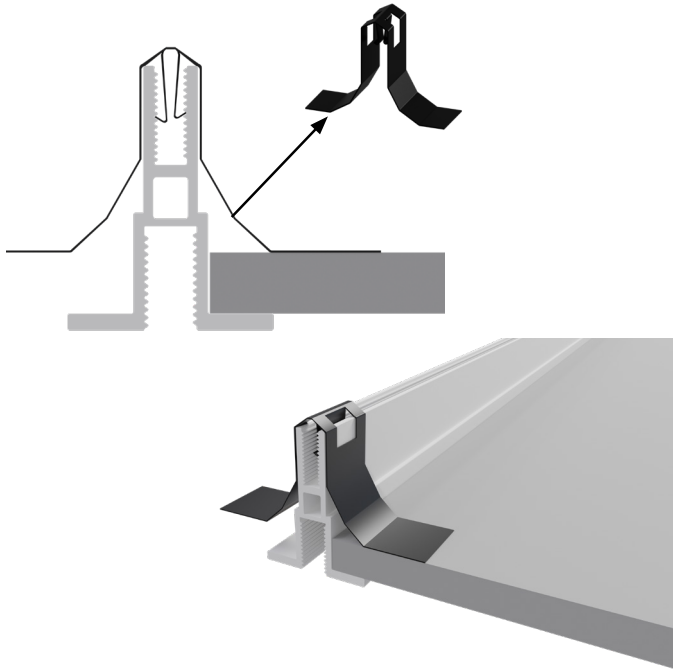

Hold Down Clips

PN44403

- Hold down clips can be provided with the Tate Grid system as an option.
- Two hold down clips are recommended per tile.
- Hold down clips are installed by pressing them into the top thread by hand or lightly tapping them with a mallet.
- Hold down clips are designed for use with 1/2" - 1" thick ceiling tiles

Performance Criteria

The bottom side of the structural grid is available with a 3/8"-16 continuous threaded slot for mounting items directly to the grid. Refer to the table below for load performance details on the grid and connections.

Structural Tee Deflection (Midspan Beam)

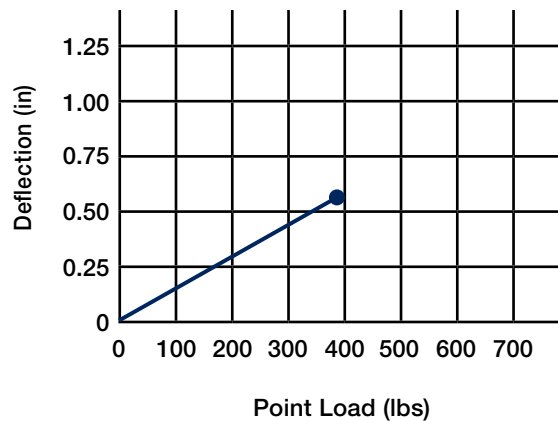
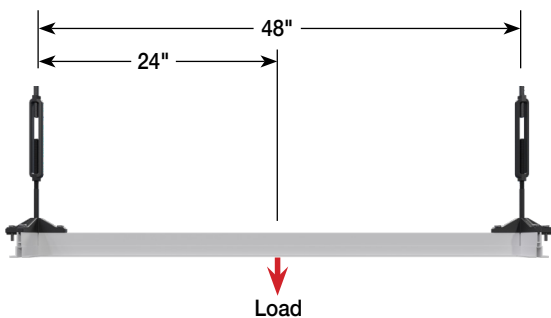

Calculate midspan beam deflection at any point below yield

$$S = \frac{WL^3}{48EI}$$

S = deflection
 W = load
 L = as noted
 E = 10x10⁶ lbs/in²
 I = .153 in⁴

On Center Hanger Spacing Module	Max Uniform Load	Max. Safe Working Load (Point Load) per module area	Mid Span Deflection @ Max. Safe Working Load	Safety Factor
4' x 4'	50 lbs / ft ²	380 lbs*	0.53"	2x

Field Connector Assembly

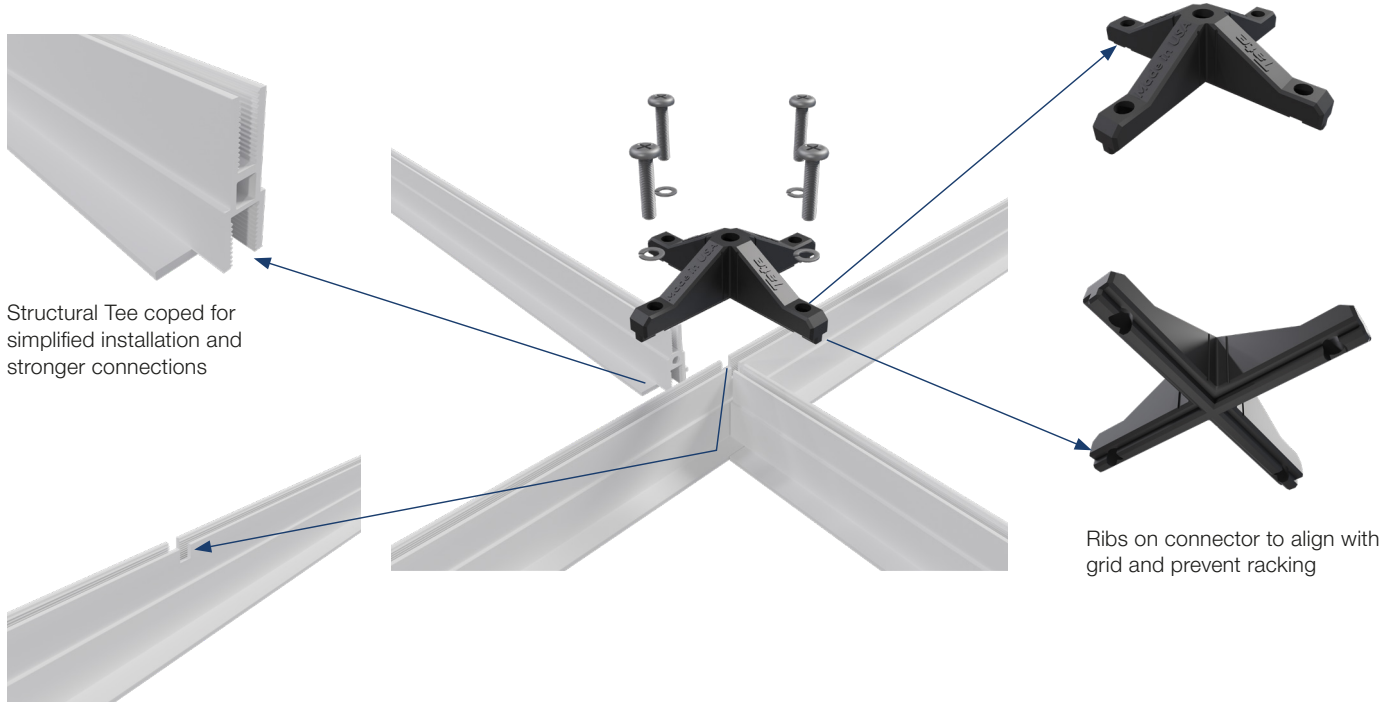

Main Runners notched to positively position connectors on center every time

XL Connector

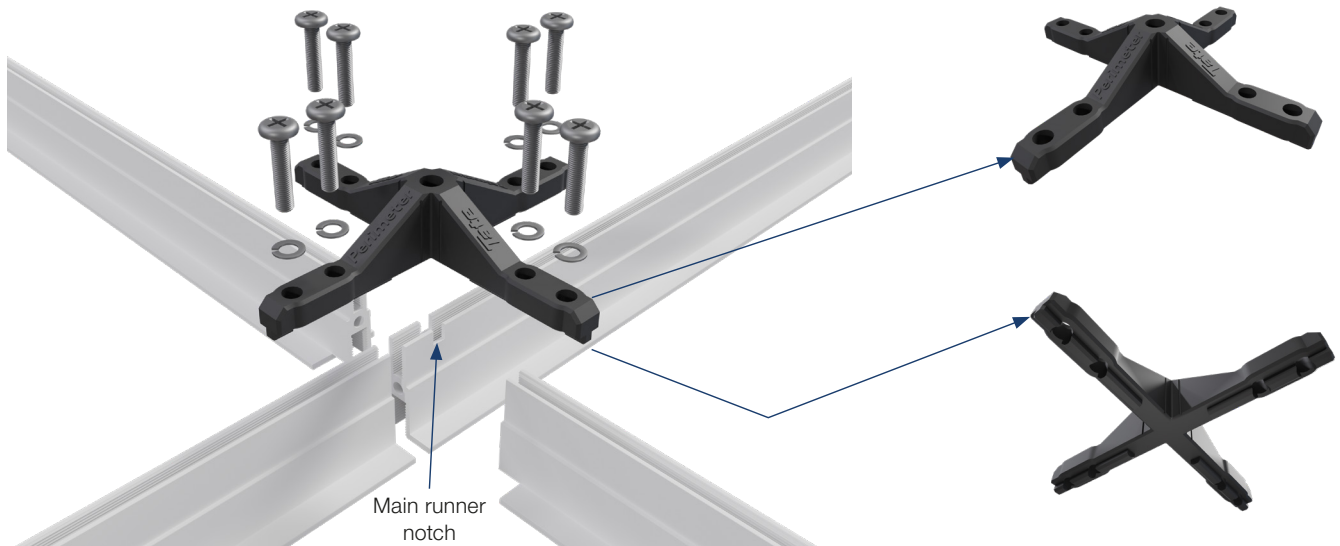

XL connector is designed for additional support at the ends of each main runner.

Perimeter Connector

Perimeter connector can be cut to be used in various locations to connect grid together.



Perimeter connector can be cut on site to be used in various locations to connect grid together.

Main Runners and Structural Tees

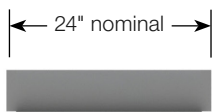

24" and 48" structural tees have coped ends which allow the grid to rest on the longer sections for stronger connections.

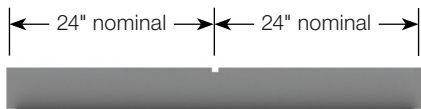

48" structural tees and 12' Main runners are notched every 24" on center for proper alignment and spacing of the connectors.

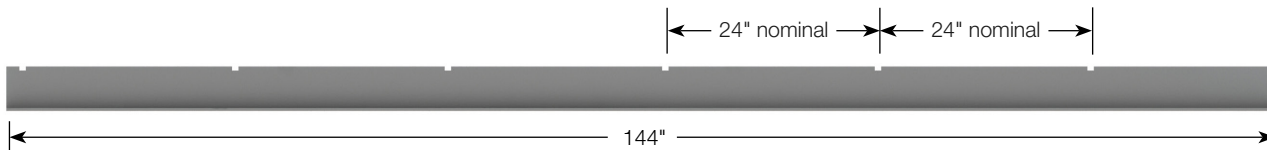

Note: Structural tee and main runner dimensions are nominal and are adjusted for custom-sized ceiling grid designs

Perimeter Details

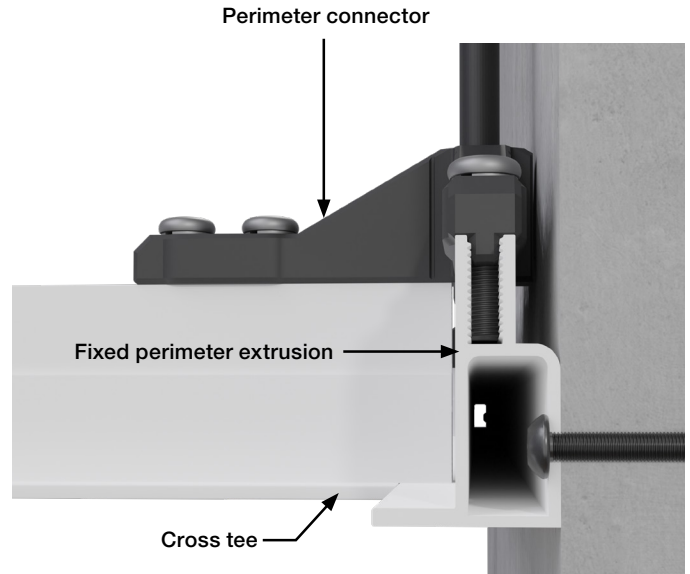
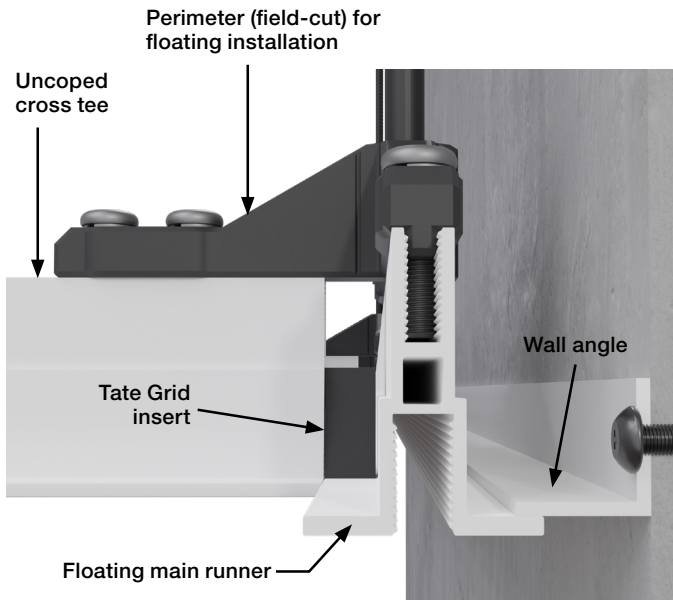

Floating Installation Detail

Main runners are utilized when installing with a floating detail. When installing with a floating perimeter, perimeter connectors can be utilized to take advantage of the notches and ribs that align extrusions and prevent racking.

Additionally it is recommended to utilize a Wall Angle attached to the perimeter.

Fixed Installation Detail

Perimeter Extrusions are designed to create a fixed perimeter detail. Perimeter Extrusions can be cut on site to desired length when assembled along perimeter walls. Perimeter Extrusions can also be bolted directly to the wall with appropriate fasteners for wall type.

Note, pre-drilling is recommended and through holes are suggested for simpler light fixture or drop ceiling tile installation.

Turnbuckle Assembly

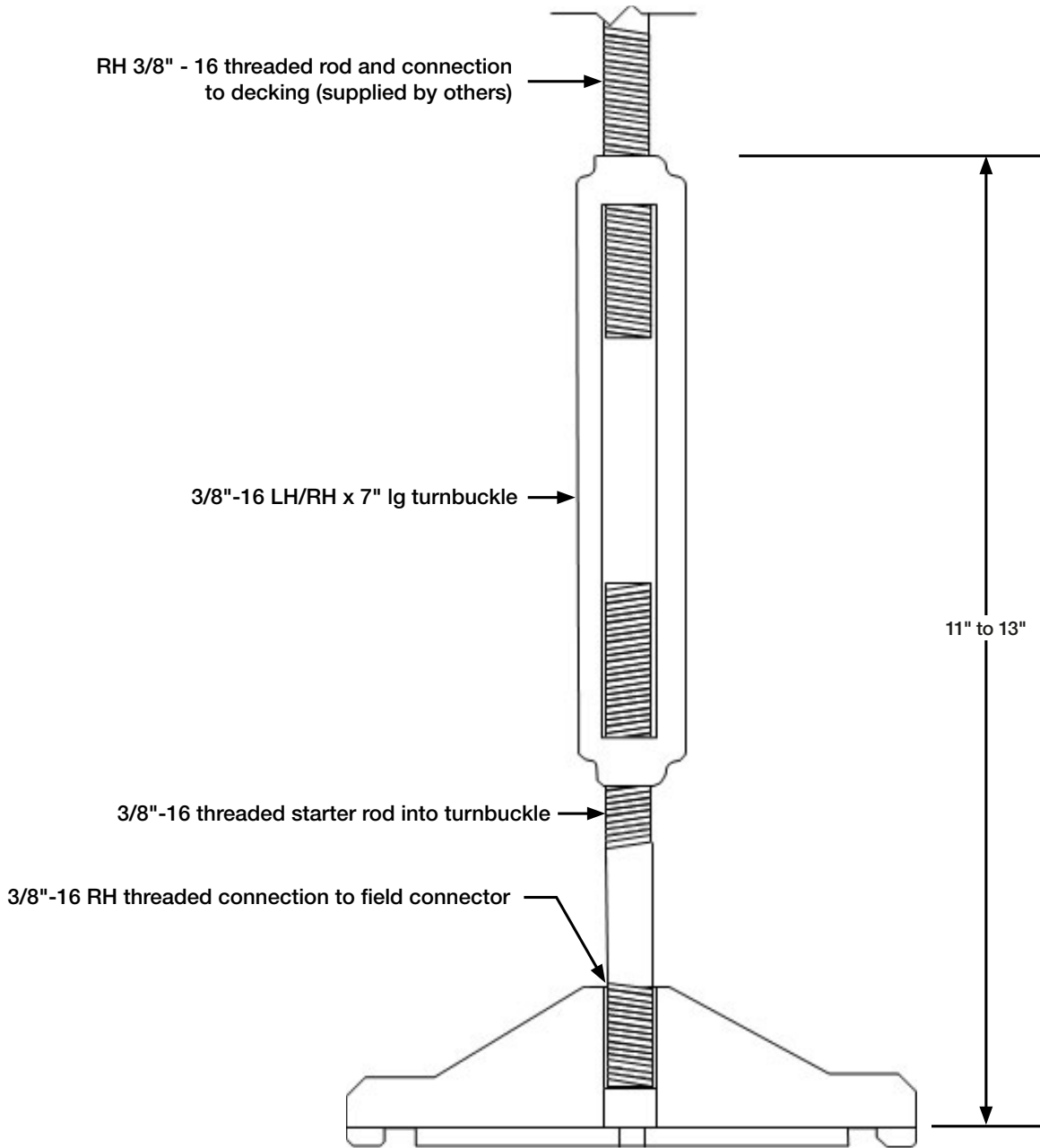

Safety Guidelines**THIS INFORMATION MUST BE SHARED WITH ALL SERVICE PROVIDERS WHO INTEND TO SUSPEND SERVICES FROM THE TATE GRID SYSTEM**

Tate Grid is a structural ceiling system designed to support static vertical loads. When installing services to the bottom 3/8"-16 threaded channel, the following instructions must be adhered to:

1. Tate Grid is limited to a maximum point load of 380lbs or distributed load of 50 lb/ft².
 - a. Exceeding these values may cause a failure in the system.
2. Torque the threaded rod or bolts between 20 in-lbs and 30 in-lbs. Over torquing will damage the threads of the 3/8"-16 slot reducing the load capacity of the Tate Grid System.
 - a. Failure to adhere to this may result in the shearing of bottom slot threads reducing the load capacity of the Tate Grid system.
3. Equal care must be taken during the installation of the Tate Grid to install the top screws connecting the Tate Grid to the suitable connector at a torque limit between 20 in-lbs and 30 in-lbs.
 - a. Failure to adhere to this may result in the shearing of top slot threads reducing the load capacity of the Tate Grid system.
4. Only screws supplied by Tate should be used on the top slot.
 - a. Failure to adhere to this may result in the reduction of the load capacity of the Tate Grid system.
5. There must be at least 5/8 in. thread engagement between threaded rod or bolt supporting the suspended service(s).
 - a. Failure to adhere to this may result in the reduction of the load capacity of the Tate Grid system.
6. Do not impose a dynamic load on the connection to Tate Grid. During installation of supported services, bracing is required to prevent dynamic load on the Tate Grid ceiling.
 - a. Moment forces imposed on the Tate Grid system may cause failure of the connection between the services and the Tate Grid system.
7. All bottom thread fixings should be completed with suitable washers.
8. Tate Grid is NOT a walk-on ceiling.
9. In certain conditions the loading capacity of the Tate structural ceiling system may be greater than the loading capacity of the building structure and/or means of attachment to the building structure. Consult with a licensed structural engineer to obtain site specific recommendations regarding the attachment of the Tate Structural Ceiling System and any associated loading to the building structure.
10. Structural ceiling systems as a whole shall be analyzed and designed to local codes by a qualified engineer.



7001 Columbia Gateway Drive, Suite 500
Columbia, MD 21046
T: 410.799.4200 E: info.amer@tateglobal.com
tateglobal.com

