

Base with Crimped Tube

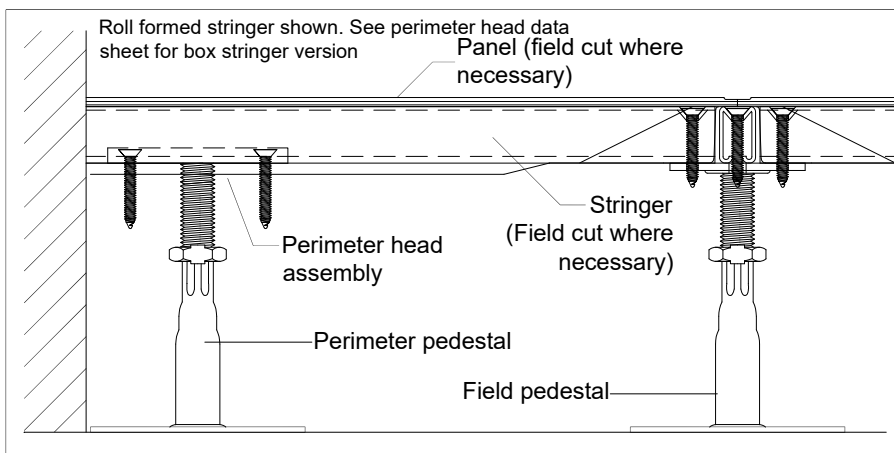

## PEDESTAL SPECIFICATIONS

### Pedestal Assembly

- Assembly up to 60" (1500 mm) FFH shall provide a 6,000 lb. (2722 kg) axial load without permanent deformation.
- Assembly shall provide a 2" (50 mm) total adjustment with a floor height of 7" (180 mm) or greater.
- Standard finished floor heights from 6" (152 mm) to 60" (1500 mm). For other finished floor heights please contact Tate. For seismic conditions, refer to seismic submittal details.
- Overturning moment of 1,000 in/lbs (5,600 cm/kgs) when Tate recommended pedestal adhesive is utilized.
- All pedestal components and fasteners are completely electro-zinc free.
- Zinc electroplating shall be prohibited on all pedestal components and fasteners.

### Pedestal Head

- Standard head is 11 ga. die formed galvanized steel pedestal head and resistance welded stud with adjustment nut. Heavy duty head for CC2000 and CC2500 panels is 8 ga. fillet welded for field and tack welded perimeter head. Head and installed stringers shall provide perimeter support for panel.
- Stringers shall be attached with 1/4" - 20 flat-head screws.
- Pedestal head shall be tapped for engagement of stringer screws
- Steel stud shall be 3/4" - 10 UNC.
- Nut shall be 3/4" - 10 UNC and galvanized.
- Stud shall provide an anti rotation feature when engaged with the pedestal base assembly (7" FFH or higher (180mm)).

### Pedestal Base

- Pedestal tube to be 1-3/4" (44.5mm) diameter hot dipped galvanized tubing and shall be reduced to 3/4" (19 mm) inner diameter by crimping.
- Base to be at least 36" (230 cm) square and hot dipped galvanized steel and shall have (4) 7/16" (11 mm) diameter holes for mechanical fastening applications.

### Stringers

- Roll formed steel stringer will withstand 450 lb. (204 kg) mid-span load.
- ConCore 2500 panels require the 4' (120cm) x .054" (1.37mm) roll formed stringer or 4' (120cm) x .048" (1.22mm) box stringer. All other panels except the ConCore 3000 and ConCore 4000 use the .048" (1.22mm) roll formed or box stringer
- All 24" jobs requiring gasketed stringers will use the box stringer regardless of panel grade
- Galvanized stringer construction to prevent corrosion.
- Stringer shall be 1-1/4" (31.75 mm) deep x 3/4" (19 mm) wide.
- Stringer grid pattern shall be 4'4" (120cm/120cm) basketweave

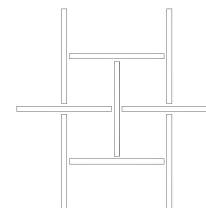

### Perimeter

- Perimeter pedestal shall provide support for panels around columns, at walls, curbs and fascia.



Tate reserves the right to amend product information without prior notice. Care has been taken to ensure that the contents of this publication are accurate, but Tate, its parent company and its subsidiary companies do not accept responsibility for errors or information that is found to be misleading or outdated. Suggestions for, or descriptions of, technical specifications and the end user or application of products are provided and must be verified prior to use. To ensure you are viewing the most recent and accurate product information, please scan the QR code.